

CLASS 1 ACCESSORY HITCH

RT-387
Toyota Prius

TOOLS REQUIRED:
DRILLS: NONE
WRENCHES: 14mm

WARNING: CONSULT VEHICLE OWNERS MANUAL FOR TOWING RECOMMENDATIONS AND LIMITATIONS. THIS HITCH IS DESIGNED AS AN ATTACHMENT POINT FOR A BIKE CARRIER OR OTHER CARGO CARRYING DEVICE. TOYOTA DOES NOT RECOMMEND TOWING A TRAILER WITH THIS VEHICLE.

WARNING: USE ONLY RIGID HITCH APPROVED AND MANUFACTURED DRAW BAR INSERT OR WARRANTY WILL BE VOID

NOTE: INSTALL PARTS LOOSELY UNTIL ALL ATTACHMENTS HAVE BEEN MADE TO VEHICLE

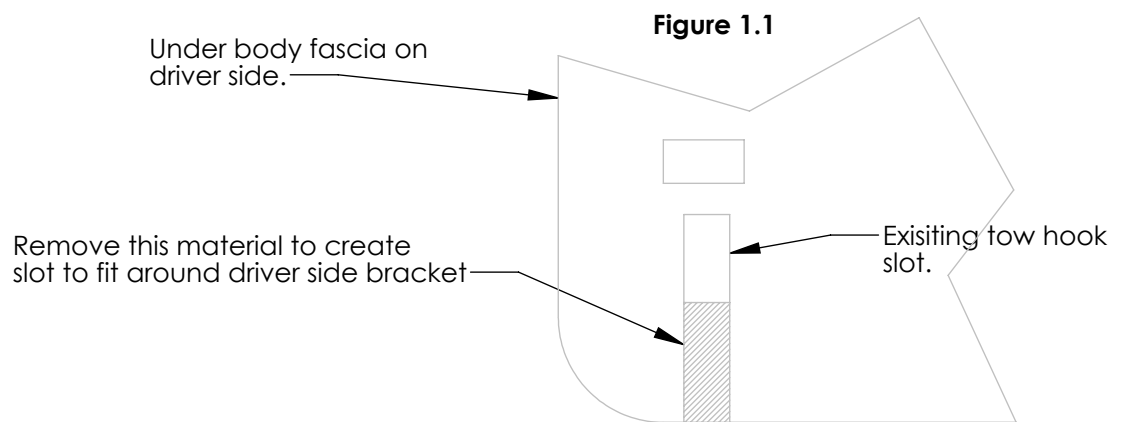
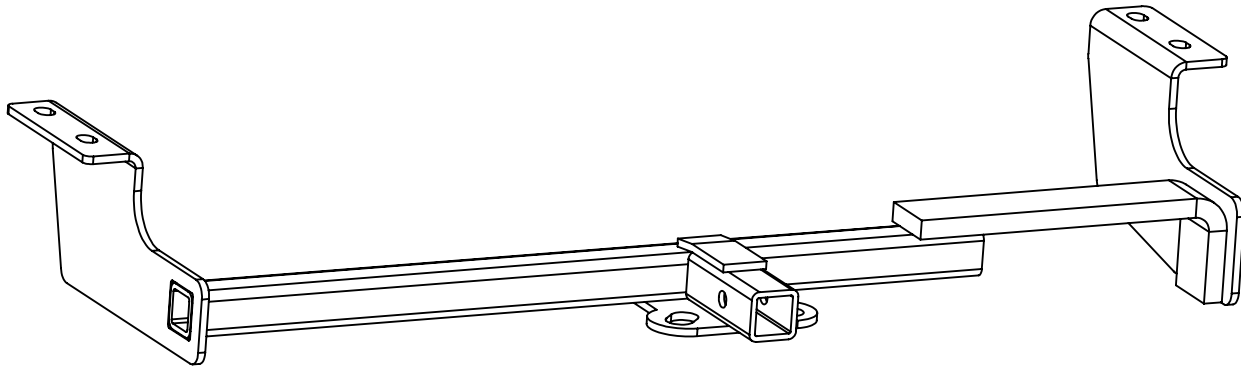

1. Temporarily remove under body fascia on driver side and modify as shown in figure 1.1.
2. Remove tow hooks from both side frame rails and return to vehicle owner.
3. Raise hitch into position and secure with 10mm bolts and conical washers provided.
4. Reinstall modified under body fascia on driver side using existing hardware.

Towing with this vehicle could void vehicle warranty

TIGHTEN ALL FASTENERS TO THE TORQUE SPECIFICATIONS SHOWN BELOW

Hardware Package:

- (4) M10 x 1.25 x 35mm hex bolts
- (4) 3/8" conical washers
- (1) UB-5001 draw bar kit

GIVE THIS INSTRUCTION SHEET TO VEHICLE OWNER

BOLT TIGHTENING TORQUE (LB-FT)			
BOLT SIZE	TORQUE	BOLT SIZE	TORQUE
3/8"	25 LB FT	8MM	20 LB FT
7/16"	50 LB FT	10MM	38 LB FT
1/2"	60 LB FT	12MM	68 LB FT
3/4"	120 LB FT		

THIS PRODUCT COMPLIES WITH SAFETY SPECIFICATIONS AND REQUIREMENTS FOR SAE AND VESC REGULATION V-5 FOR CONNECTING DEVICES AND TOWING SYSTEMS. DO NOT MODIFY THIS PRODUCT. INSTALL ONLY ON SPECIFIED VEHICLES IN GOOD CONDITION.

RIGID[®]
HITCH INCORPORATED
3301 WEST BURNSVILLE PARKWAY
BURNSVILLE, MN 55337
www.rigidhitch.com

REV.
08/07